

## Resin

Resin Type

Resin Name

Resin Color

Resin Density  g/ml

Resin Cost  \$ /

## Print

Layer Height  mm

Bottom Layer Count

Exposure Time  s

Bottom Exposure Time  s

Transition Layer Count

Transition Type

Transition Layer Interval Time Difference  s

Waiting Mode During Printing

Rest Time Before Lift  s

Rest Time After Lift  s

Rest Time After Retract  s

Bottom Lift Distance  +  mm

Lifting Distance  +  mm

Bottom Retract Distance  +  mm

Retract Distance  +  mm

Bottom Lift Speed  +  mm/min

Lifting Speed  +  mm/min

Bottom Retract Speed  +  mm/min

Retract Speed  +  mm/min

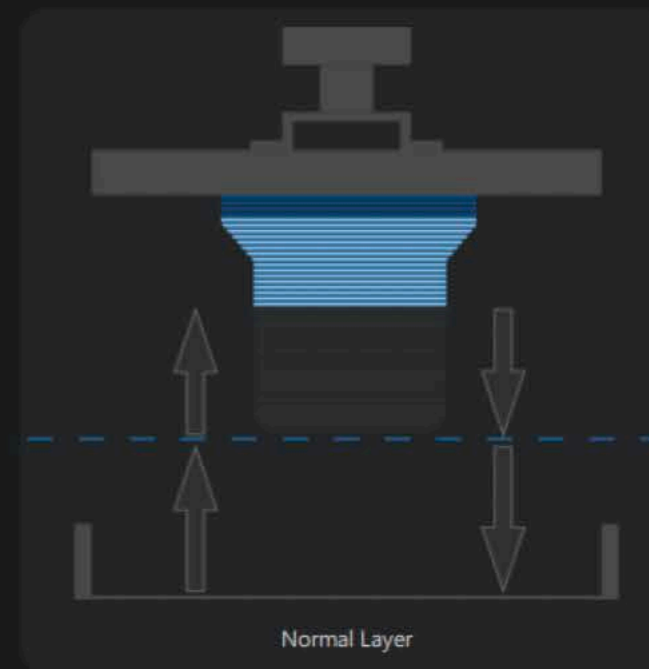
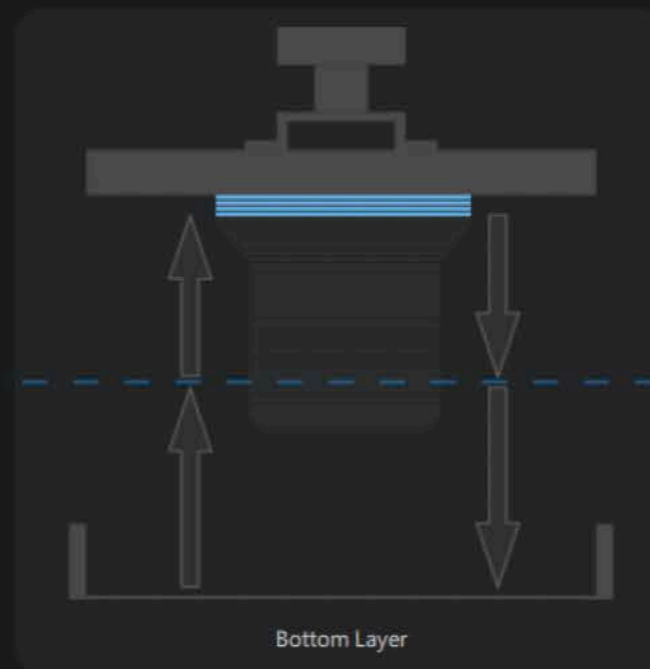

## Advance

Bottom Light PWM

100

%

Light PWM

100

%

Picture Grayscale

255

Anti-Aliasing

Gray Scale Level

Gray Scale Level

1

2

3

4

5

6

7

8



127

255

Image Blur Enable

Image Blur Pixel

2

Shrinkage Compensation

X: 100.806 %

Y: 100.671 %

Z: 100.000 %

Tolerance Compensation

Bottom Tolerance Compensation

Print Time Compensation

Mask